

ACCESSORIES

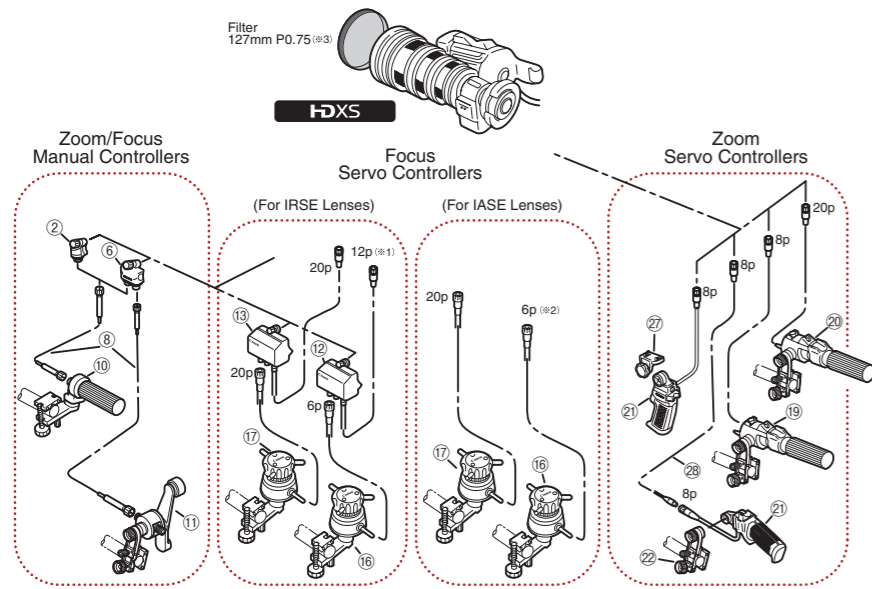

#	Unit	Description
②	FFM-100	Flex Focus Module
⑥	FFM-200	Flex Dual Module
⑧	FC-40	Flex Cable
⑩	FFC-200	Flex Focus Controller
⑪	FZC-100	Flex Zoom Controller
⑫	FPM-420	Focus Positional Servo Module
⑬	FPM-420D	Focus Positional Servo Module
⑯	FPD-400**4	Focus Positional Demand
⑰	FPD-400D	Focus Positional Demand
⑲	ZSD-300M	Zoom Servo Demand
⑳	ZSD-300D	Zoom Servo Demand
㉑	ZSG-200M	Zoom Servo Grip
㉒	CR-10	Clamper
㉓	ZGA-500	Grip Adapter
㉔	EC-80	Zoom Extension Cable (8P)

(※1) CC-2012 conversion cable is necessary to connect between IRSE Digital Drive Lens and FPM-420.
 (※2) CC-2006 conversion cable is necessary to connect between IASE Digital Drive Lens and FPD-400.
 (※3) For the optical accessories, the 127mm diameter P0.75 filters are applicable. The filters are to be attached to the threaded hood unit. (UV/ Clear/ Cross/ Snow Cross/ Sunny Cross/ Polarized Light/ Softon/ ND8)
 (※4) FPD-400 is not available from Canon stock.

DIMENSIONS

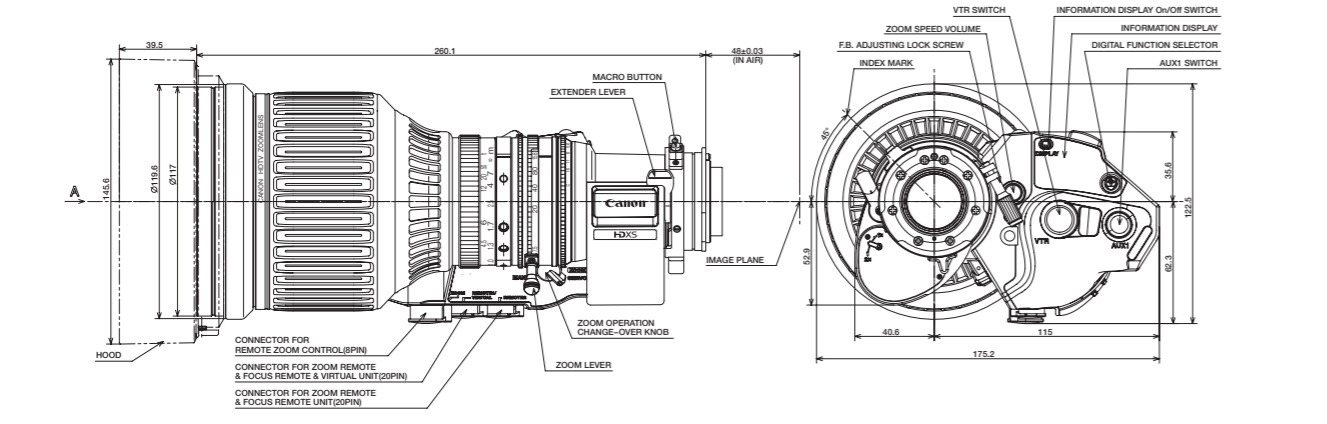

North & South America
Canon U.S.A., Inc.

Broadcast & Communications Div. (Headquarters)
 65 Challenger Road, Ridgefield Park, NJ 07660
 Tel: (201) 807-3300 / (800) 321-4388
 Fax: (201) 807-3333
 Email: bctv@usa.canon.com
 http://www.canonbroadcast.com/

Chicago

100 Park Blvd. Itasca, IL 60143
 Tel: (630) 250-6236 Fax: (630) 250-0399

Atlanta

5625 Oakbrook Pkwy. Norcross, GA 30093
 Tel: (770) 849-7890 Fax: (770) 849-7888

Los Angeles

15955 Alton Parkway Irvine, CA 92618
 Tel: (949) 753-4330 Fax: (949) 753-4337

Dallas

3200 Regent Blvd. Irving, TX 75063
 Tel: (972) 409-8871 Fax: (972) 409-8869

Latin America

Tel: (954) 349-6975 Fax: (201) 807-3333

Canada

Canon Canada, Inc.
 Broadcast and Communications Div.
 6390 Dixie Road
 Mississauga, Ontario, L5T 1P7, Canada
 Tel: (905) 795-2012 Fax: (905) 795-2140

Europe/Africa/Middle East

Canon Europa N.V.
 Broadcast and Communications Div.
 Bovenkerkenweg 59-61
 1185 XB Amstelveen
 Tel: +31 (0) 20-5458905 Fax: +31 (0) 20-5458203
 Email: tvprod@canon-europe.com
 http://www.canon-europe.com/tv-products

Australia

Canon Australia Pty. Ltd.
 Optical Products Division
 1 Thomas Holt Drive, North Ryde, NSW 2113,
 Australia
 Tel: +61 (0) 2-9805-2000 Fax: +61 (0) 2-9805-2444

China
Canon (China) Co., Ltd.

Optical Products Division
 15F Jinbao Building No. 89 Jinbao Street
 Dongcheng District, Beijing 100005, China
 Tel: 86-10-85139999 Fax: 86-10-85139902
 http://www.canon.com.cn

Asia/Japan
Canon Inc.

(Broadcast Equipment Group)
 23-10, Kiyohara-Kogyo-Danchi, Utsunomiya-shi,
 Tochigi-ken, 321-3298, Japan
 Tel: +81 (0) 28-667-8669 Fax: +81 (0) 28-667-8672
 http://www.canon.com/bctv

Distributed by

Canon <http://www.canon.com/bctv>



HJ21ex7.5B

NO SCENE WILL FAIL TO YIELD TO THE IMAGING PROWESS OF CANON'S HD PRODUCTION LENS



INNOVATION
 In TV Optics Since 1958



Specifications subject to change without notice.

HJ21ex7.5B

HDXS

NO SCENE WILL FAIL TO YIELD TO THE IMAGING PROWESS OF CANON'S HD PRODUCTION LENS



The overall demand for HD production coupled with the growing diversity of production applications has called for an expansion in the range of HD lenses. The HJ21ex7.5B was specifically developed to support high-end HD production where minimization of focus breathing (unwanted alteration to angle of view that accompanies manipulation of the focus control), high imaging performance, extended focal range and a modestly wide angle constitute core production requirements for drama and documentary program origination. With the addition of the new digital drive unit the shooting versatility is further enhanced. The 7.5mm wide angle setting and the 21x zoom ratio offer a formidable operational combination for such high-end production work.

(New drive is loaded with the lens that has 'A' at the end of its model name such as 'IRSE A', 'IASE A'.)

MAIN FEATURES

Specifically Designed for High-end HD Production

Focus breathing and variations in picture performance with refocusing at different object distances have been traditional imaging challenges to high-end production calling for high picture quality. By adopting the novel 3-group inner focus system and setting a proper power for the front lens fixed group as well as the focus moving group, the HJ21ex7.5B succeeded in minimizing such unwanted phenomena to an exceedingly low level. Also the lens is designed to maintain high optical performance across the entire 16:9 image plane, especially at the telephoto side of the focal length. Within the standard BCTV lens lineups consisted of Wide, Standard and Telephoto lenses, the addition of the HJ21ex7.5B establishes its own important category supporting the special imaging requirements of the high-end HD production market.

High Imaging Performance with Special Optical Elements and Exclusive Optical Layout

With the goal of minimizing various aberrations in order to meet the imaging standards of high-end production, the HJ21ex7.5B adopts special optical elements that include the artificially re-crystallized "Fluorite" featuring extraordinary dispersion characteristics and the newly developed high index ultra low dispersion glass, "Hi-UD" glass. These lens elements are scientifically exploited by the design of an optical layout exclusive to this particular lens. The imaging achievement can be seen in its high optical specifications and extraordinary performance. Featuring a broad focal length range of 7.5mm to 158mm and a maximum relative aperture of F1.9, the lens maintains its high optical performance throughout the entire zoom range.

Exceptional High Optical Performance

High MTF, Minimized Chromatic Aberrations and Countermeasures against Ghosting and Flares



Special Optical Elements

Improved Operability & Reduced Operator Fatigue

Coupled with innovations in optical performance, is a totally new design of the digital drive unit. Refined by long-term market research and worldwide experience, Canon mobilized the latest in 3D CAD-CAM design to significantly improve the human tactile interface to the control of zoom, iris, and focus. Here are some results of Canon's research:

Reduced Physical Stress

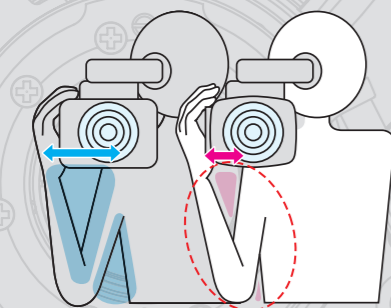

By reducing the width of the drive unit, the palm of the camera operator's hand is positioned closer to the optical axis, thus reducing the degree of arm bend which in turn lessens physical stress during prolonged shooting.

Improved Ease of Operation

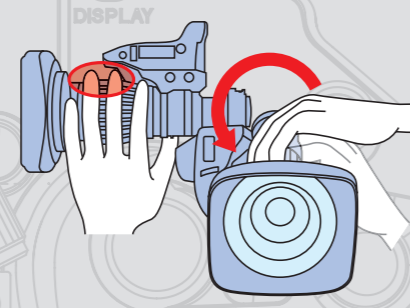

The spacing between the focus ring and drive unit has been changed to avoid accidental interference with the drive unit while manipulating the focus control.

Ergonomic Design

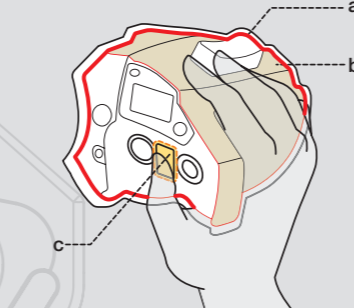

The size and curvature size have been optimized to more comfortably fit in the palm of the operator's hand (a). Newly developed coatings improve the tactile interface between the user and the drive unit (b) together with the new Rubber Grip Support (c).

Enhanced Digital Drive Unit

Information Display

Zoom Speed Volume in New Location

New Rubber Grip Support



The incorporation of miniature 16-bit, high resolution Rotary Encoder Devices into the new enhanced digital drive unit, has extended the features of the HJ14x to include:

- Precision control of all lens operations
- Precise digital repeatability of zoom, focus and iris control that support innovative image creation
- Simple and direct digital integration into virtual studio systems
- Precision zoom control over a total speed range of 0.5 sec. to more than 5 min.

Moreover, Canon's unique Information Display provides easy, precise customization of the enhanced digital functions.

Enhanced Digital Functions

Shuttle Shot

By memorizing any two focal lengths, the Digital Drive can automatically "shuttle" between the two points, moving in either direction.

Frame Preset

An angle of view can be preset in either of two memories and the lens will zoom at the highest speed or in a preset zoom speed to the preset position by pushing a simple button.

Speed Preset

A specific zoom speed can be preset in memory and it is possible to repeat the zoom speed as often as you like by pushing a simple button.

Extremely small Focus Breathing

Newly Designed Ergonomic Drive Unit



2.0x Extender

Zoom Ratio 21x and Wide Angle of 7.5mm Dynamic Zoom Speed Range (0.5sec-5min from wide end to tele end)

Extremely High Optical Performance

High MTF, Minimized Chromatic Aberrations and Innovative Countermeasures against Ghosting and Flares



Starting Point Preset Position Starting Point



Starting Point Frame 1 Frame 2



Zooming in same speed

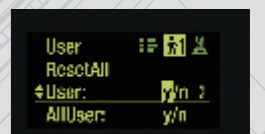

Information Display

SPECIFICATIONS

HJ21ex7.5B	16:9		4:3	SWITCHABLE 4:3	
	1.0x	2.0x	1.0x	1.2x	2.4x
Built-in extender					
Zoom Ratio	21x				
Range of Focal Length	7.5~158mm	15.0~316mm	6.2~130mm	7.5~158mm	15.0~316mm
Maximum Relative Aperture	1:1.9 at 7.5~116.0mm 1:2.6 at 158mm	1:3.8 at 15.0~232.0mm 1:5.2 at 316mm	1:1.9 at 6.2~116.0mm 1:2.15 at 130mm	1:1.9 at 7.5~116.0mm 1:2.6 at 158mm	1:3.8 at 15.6~232.0mm 1:5.2 at 316mm
Angular Field of View	65.2°×39.6° at 7.5mm 3.50°×2.00° at 158mm	35.5°×20.4° at 15.0mm 1.70°×1.00° at 316mm	60.8°×47.5° at 6.2mm 3.20°×2.40° at 130mm	51.3°×39.6° at 7.5mm 2.60°×2.00° at 158mm	27.0°×20.4° at 15.0mm 1.30°×1.00° at 316mm
Minimum Object Distance (M.O.D)	0.85m (10mm with Macro)				
Object Dimensions at M.O.D	120.4×67.7cm at 7.5mm 5.60×3.20cm at 158mm	60.2×33.9cm at 15.0mm 2.80×1.60cm at 316mm	110.1×82.6cm at 6.2mm 5.10×3.80cm at 130mm	89.3×67.0cm at 7.5mm 4.20×3.20cm at 158mm	44.7×33.5cm at 15.0mm 2.10×1.60cm at 316mm
Approx. Size	W×H×L=175.2×122.5×260.1mm				
Approx. Mass (IRSE A / IASE A)	2.61Kg(5.76lbs) / 2.69Kg(5.94lbs)				

HJ21ex7.5B IRSE A Zoom: Servo / Manual Focus: Manual
HJ21ex7.5B IASE A Zoom: Servo / Manual Focus: Servo / Manual